

CT-PX2E - User Guide



www.pixeltechnologies.com.au



SCAN or CLICK
QR Code
Access our online product
documentation page

Description [↗](#)

The CT-PX2E is a multi-protocol elevator encoder that enables seamless communication between a CAN elevator controller and Pixel Technologies' Ethernet and DataBus enabled elevator displays, touch displays, and audio devices. Designed with a compact industrial form factor, it provides a reliable and efficient solution for elevator and landing encoder applications.

Wiring Overview & Installation [↗](#)

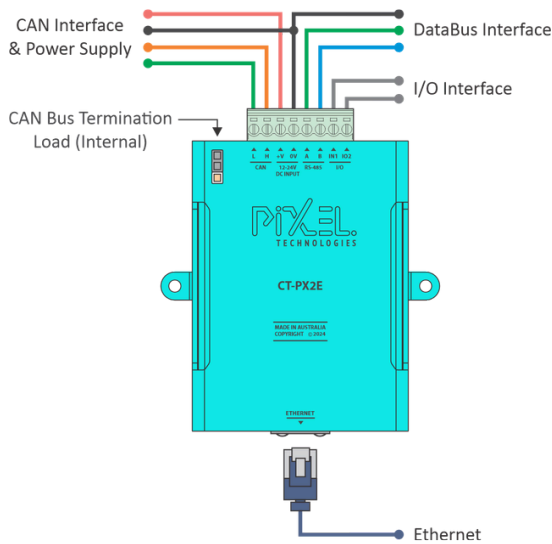

i If the CT-PX2E is the last device on the CAN bus, set the internal jumper to the EOL (End-of-Line) position to enable the required 120-ohm CAN bus termination.

1. Install the CT-PX2E at the desired location.
2. Remove the green terminal plug from the module.
3. Connect the CAN bus power source to the Input (V+/0V).
4. Connect the CAN bus (CANH/CANL) interface.
5. Re-insert the green terminal plug.
6. Connect a CAT6 cable from the Ethernet interface to the elevator cabin display networking switch.

System LED Indicators [↗](#)

	No CAN Data Rx	CAN Data Rx	I/O Activated
	● Red	● Green	● Blue
No Wi-Fi (Idle)	Blink 0.5s		Blink Once 1s
Wi-Fi Available	Blink 0.25s		
Wi-Fi Connected	ON		

Configuration [↗](#)

The CT-PX2E is typically a plug-and-play solution when connecting to Pixel elevator displays and audio devices via the DataBus interface. However, when interfacing with Pixel's displays over Ethernet, additional configuration is required.

After powering on the device, a CT-PX2 Wi-Fi network will become available for up to **5 minutes**.

Access device Web Server [↗](#)

1. On your laptop or smartphone, navigate to available Wi-Fi networks.
2. Look for Wi-Fi network labeled `CT-PX2E_<device-serial-number>` select it & enter the password `12345678` to connect.
3. Launch your web browser (e.g. Google Chrome) and enter `192.168.4.1` into the URL bar.
4. Once connected to the CT-PX2 Encoder Module's web server, go to the **Configuration** tab.

Floor Mapping [↗](#)

Enter Floors and click **Generate Labels** to map the display and/or touch button labels to floor indices & click **Save Floor Labels**.

Message Mapping [↗](#)

Ensure Default Mapping matches the Pixel elevator display config. For alternate mapping, configure & click **Update Mapping**.

Ethernet Network Settings [↗](#)

1. Assign a unique static IP address. Pixels' typical IP schema for encoder modules is `10.100.1.1xx` (where **xx** is the elevator number, e.g. `01` for elevator 1). **Factory Default IP:** `10.100.1.150`
2. Set a Multicast Group Name and Multicast IP to communicate with displays within the elevator.
 - a. Group Name = `Lift x` (where **x** is the elevator number/letter)
 - b. Group Address = `239.255.0.x` (where **x** is the elevator number)
3. Click **Update Network Settings**

Once configuration is complete, click on the **Terminate Wi-Fi** button to return the CT-PX2E to normal operation.

Technical Specifications [↗](#)

Operating Voltage	12 - 24V DC
Operating Current	12V: 75mA (140mA with Wi-Fi Active) 24V: 40mA (75mA with Wi-Fi Active)
RS-485 Interface	DataBus (Mode 3), up to 64 end-devices @ 400m (max)
CAN Interface	CAN FD Transceiver (Multi baud)
Ethernet Interface	10/100 Base-T/TX
Wi-Fi Access Point	802.11b/g/n
I/O Interface	Input: Dry Contact (Active Low) Output: Open-Collector (30V DC, 100mA max)
Mounting	Wall Mount, Din-Rail (Requires additional DIN rail bracket)
Operating Temperature	0 - 50°C
Operating Humidity	90% max RH, non-condensing